

## Lascaux Accessories

---

### High Tech Porcelain Spatula

The Spatula is made from high-tech porcelain which does not leave any unwanted residue from abrasion. This removes the danger of contamination from any leftover particles and resulting discolouration as is the case with metal. Its robust working surface is thin and flexible. The specially cut segments prevent the spatula from rolling off the working surface.

### Membrapack

This packaging box is ideal for transporting samples. The elastic membranes inside the box adapt perfectly to every shape and hold items securely.

### Ozclip

Ozclip is a multi-purpose hanging and storage fitting, designed as a permanent attachment to framed artworks. Ozclip eliminates the need for expensive and labour intensive fittings each time a painting is moved. Ozclip holds the painting in the most secure way while hanging or travelling.

The Ozclip can be used as an additional security measure in deterring theft. No longer is it necessary to drill and redrill frames for special fittings each time a painting is moved. These operations weaken and eventually ruin frames. Ozclip offers a system whereby one attachment is suitable for a life time of security, hanging, storage and travel operations. Ozclip is compatible with existing hanging techniques and can be used with most travelling and storage frames and cases.

#### Installation instructions

The Ozclip hanging system consists of two types of clips:

- a) the Ozclip hanging device, with stainless steel loop for attachment to hanging wire;
- b) the Ozclip holding device, without loop for permanent attachment, but used in transportation only.

Together the Ozclip devices provide a permanent attachment system of hanging and transportation. In larger artworks more than one Ozclip holding device may need to be used.

1. Place the painting face down, making sure that the surface of the painting will not snag on the table surface or that any impasto is in danger of being crushed. The frame may help to protect the painting, but placement on cushioned blocks is recommended.
2. The Ozclip hanging device is provided with a loop of stainless steel to provide a means of attachment to a hanging system, i.e. chain, wire, cord, etc. In accordance with the type of hanging system used, calculate the distance from the top edge of the right

side of the frame, so that the point of attachment is hidden by the frame when the painting is on exhibition. The hanging device should be placed as close as possible to the side edge of the frame to allow sufficient clearance for the holding arm when in use for transit.

Make sure that the wood of the frame or stretcher is solid at the point of attachment and that the length of the screws used are appropriate for the weight of the painting and frame.

3. Take the Ozclip hanging device face up (side with writing on it) and open the holding arm out to 90°, revealing the screw holes on the base bar.
4. Using 8 gauge, self tapping, Philips Head screw of the appropriate length, screw the Ozclip onto the frame or stretcher, making sure that the head of the screw does not protrude above the surface of the base bar, as this will obstruct the free movement of the holding arm.
5. The Ozclip holding device is the component without the stainless steel loop. It should now be placed on the frame or stretcher towards the bottom edge. If the frame and painting are heavy, an additional Ozclip holding device may be added in the middle of the side member of the frame. This will help to spread the load.
6. Take the Ozclip holding device face up, with the pivot pin uppermost, and open the holding arm out to 90°, revealing the screw holes in the base bar.
7. Using 8 gauge, self tapping, Philips Head screws of the appropriate length, screw the Ozclip onto the frame at the allocated places.
8. By folding out the holding arm from the bottom of the hanging device and from the top of the holding device, the unit is self-bracing whilst in the travelling mode.
9. Once installed, fold back the holding arms so that the screws are covered. The Ozclips are now in the exhibition mode.
10. Carry out the same procedure for the left side of the painting.
11. The Ozclips are now a permanent fixture to the frame or the unframed painting, whilst on display or transit. The holding arm can be folded down and fixed to the wall as a security measure.

#### Use of Ozclip in travelling mode

Ozclip converts to a robust travel bracket instantly by simply folding out arms. Wing nuts will secure the painting. Frame and rehanging is all achieved without redrilling or attaching other devices. The following procedures should be followed:

1. Fold out the holding arms of the Ozclips to a 90° angle to the side of the frame or painting.
2. Prepare the crate, travelling frame or traveltray, so that the braces are in the appropriate places to install the painting using Ozclips.
3. With the painting face up, position in the traveltray. The holding arms of the Ozclip should be protruding from the sides of the painting's frame. The successful use of the

Ozclip in the travelling mode is totally dependant on the right angles working against each other to form a self-bracing unit.

4. Mark where the hole of the Ozclip holding arm will be positioned. Remove the painting.
5. Drill holes in the braces where marked, for the installation with the Ozclips. The brace may be covered with a thin layer of cushioning material. However this does not provide cushioning for the total package weight of the painting, frame and traveltray. Cushioning for this total package weight should be calculated and then be placed at the interface where traveltray and crate meet.
6. From the back of the traveltray, place the bolt through the hole. Capture the bolt with a nut on the front.
7. The painting fitted with Ozclips should now be placed in the traveltray with its face up, and the Ozclip holding arms should now fit down over the captured bolts.
8. Place washers over the front of the Ozclip holding arms and secure with wing nuts.
9. To further ensure that there is no movement of the art work during transit, the option exists to fit blocks of appropriate cushioning around the edges.

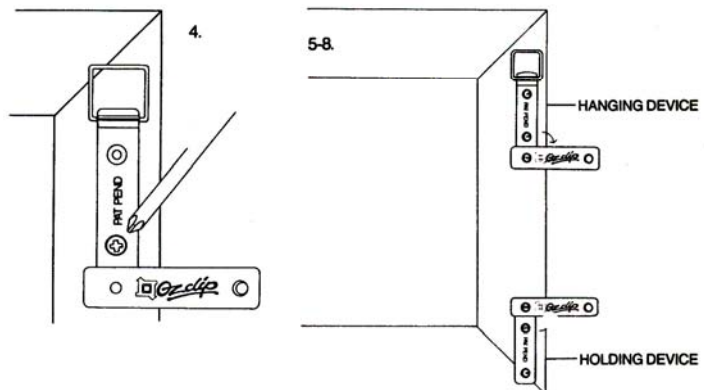
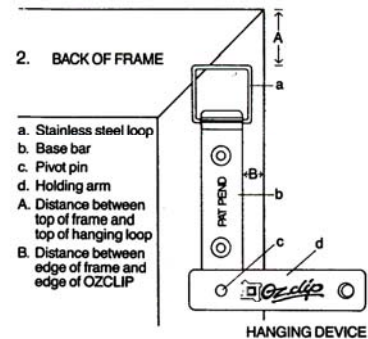
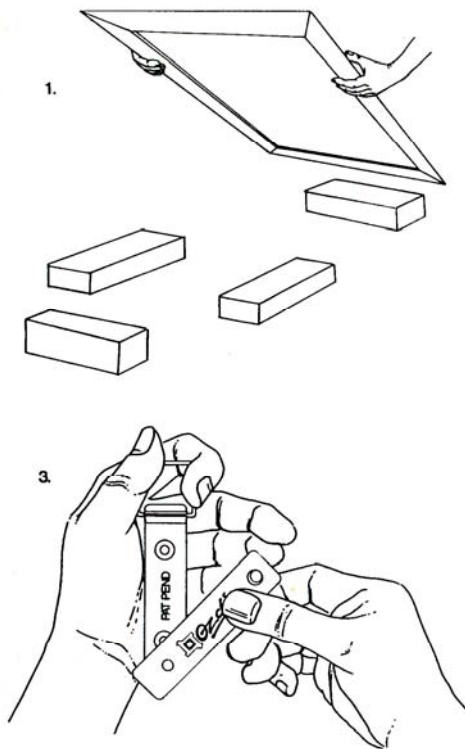

**Disclaimer:**

The information provided above is given to the best of our knowledge and is based on our current research and experience. It does not absolve the user from the responsibility of first testing the suitability of our products for the specific use conditions he or she has in mind. This technical sheet will become invalid with any revised edition. The latest update is always found on our website.